

Fresh'n Squeeze®

Multi-Fruit Juicer

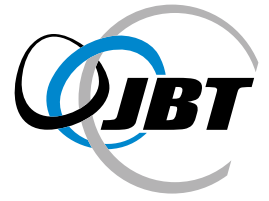

[Read More](#)



The Perfect Squeeze™

Image Builder

The ultimate point-of-sale image builder, freshly squeezed orange juice and lemonade made in view of your customer fresh every day is perfect for hotels, restaurants, coffee shops, grocery stores and juice bars.

So, if your plans call for offering a fresh and natural product like fresh squeezed orange juice or fresh squeezed lemonade, let your consumers experience juices made with the Fresh'n Squeeze Multi-Fruit Juicer.

Whole Fruit Extraction Principle

JBT extraction technology provides customers with a compact juicer that uses the same patented "whole fruit extraction principle" used in JBT's industrial extractors the global leader in citrus juice processing technology.

JBT extractors currently process over 75% of citrus juices produced worldwide.



Stainless Steel Model



ABS Model

Juice Quality

The basic principle of instantaneous separation is the major reason for the superior quality juice delivered by the Fresh'n Squeeze Multi-Fruit Juicer.

The design of our juicer instantaneously separates juice from peel, seed and albedo components which, if allowed to stay in contact with the juice, have an adverse effect on flavor.

Juice Yield

The Fresh'n Squeeze Multi-Fruit Juicer yields up to 50% more juice per unit of fruit than any other point-of-sale juicer.

Our unique design allows the juicer to process the widest range of fruit sizes and all citrus varieties including oranges, grapefruit, lemons, limes, and tangerines.



Really fresh, really good, and really profitable

Juice yield 50%

Technical Specifications (metric shown in brackets)

Throughput	20 fruit per minute
Fruit hopper capacity	40 lbs. (18 kg) - 1 carton
Processing speed	80-120 quarts (76-114 liters) per hour
Reservoir capacity	3-1/2 gallons (13 liters)
Electrical requirements (USA)	0,75 kw, 115 volts, 60 Hz, 20 amp service, single phase
Electrical requirements (export models)	0,23 kw, 110/220 volts, 50/60 Hz, 20/10 amps service, single phase (dedicated circuit required)
Safety features	Completely enclosed, safety interlock switches
Finish	High impact, flame retardant ABS or stainless steel (optional)
Weight	535 lbs. (243 kg), Shipping Wt. 570 lbs. (259 kg)
Waste container	Holds 40 lbs. (18 kg)

Standard Citrus Juicing Components

Average fruit size	diameter 2-1/2" (63.5 mm) to 3-7/8" (98 mm)
Orange count	Per 40 lb. (18 kg) Carton, 138 to 48
Grapefruit count	Per 40 lb. (18 kg) Carton, 56 to 48
Lemons, limes count	Per 40 lb. (18 kg) Carton, 138 to 95
Versatility	Juices all types of citrus fruit without adjustment
Optional	Strainer tubes for various juice pulp requirements

Approximate Specifications

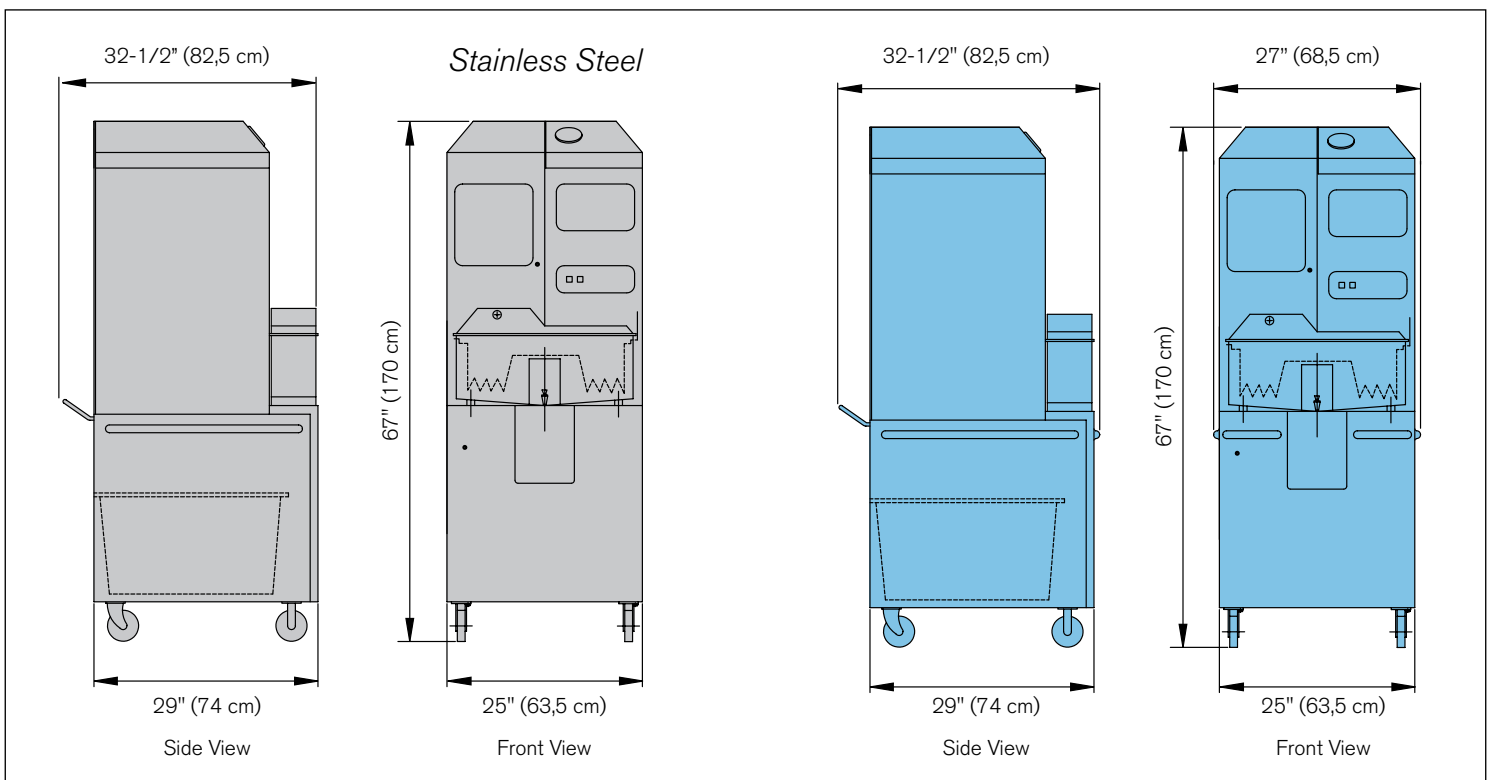



Corporate Social
Responsibility
at JBT

We are your single source for profitable processing solutions

JBT is a leading provider of integrated food processing solutions.

From single machines to complete processing lines, we enhance value and capture quality, nutrition and taste in food products.

With a local presence on six continents, JBT can quickly provide our customers and partners in the food processing industry with the know-how, service, and support needed to succeed in today's competitive marketplace.

Part of the technology presented in this brochure may be patented. JBT, whose policy is to continuously improve its products, reserves the right to discontinue or change specifications, models or design without notice and without incurring obligation.



www.jbtcorporation.com

Or for specific product line:
www.freshnsqueeze.com

North America

John Bean Technologies Corporation
400 Fairway Avenue
Lakeland, FL 33801
USA
Phone: +1.863.683.5411
Fax: +1.863.680.3672
citrus.info@jbt.com

Latin America

JBT de México S de RL de CV
Camino Real a San Andrés Cholula No. 2612
Col. San Bernardino Tlaxcalancingo
72820 San Andrés Cholula, Puebla
México
Phone: +52.222.329.4902
Fax: +52.222.329.4903
citrus.info@jbt.com

South America

John Bean Technologies Máq. e Equip. Ind. Ltda.
Av. Eng Camilo Dinucci 4605
14808-900 Araraquara, São Paulo
Brazil
Phone: +55.16.3301.2000
Fax: +55.16.3301.2144
latinamerica.info@jbt.com

Europe

John Bean Technologies SpA
Via Mantova 63/A
43122 Parma
Italy
Phone: +39.0521.908.411
Fax: +39.0521.460.897
sales.parma@jbt.com

South Africa

John Bean Technologies (Pty) Ltd.
Koper Street
Brackenfell
Cape Town, South Africa 7560
Phone: +27.21.982.1130
Fax: +27.21.982.1136
capetown.parts@jbt.com

Asia Pacific

John Bean Technologies (Shanghai) Co., Ltd.
Room 1908, Hongwell International Plaza,
1600 West Zhongshan Rd.,
Xuhui District, Shanghai 200235,
China
Phone: +86.21.3339.1588
Fax: +86.21.3339.1599
infoasia-jbtfoodtech@jbt.com