

THE FRESH FRUIT EXPERIENCE



Cylinder



Spears



READY TO
GO IN JUST
10
SECONDS



- ✓ Increase Pineapple sales by an average of 300%
- ✓ Increase Repeat Customers and Overall Store Sales
- ✓ Increase Branding (custom wrap available)
- ✓ Decrease Labor Costs
- ✓ Blade Options for Cylinder or Spears



Customer service and parts
are always available!

Profit while promoting good health.

800-627-2886 • sales@juicernet.com • www.juicernet.com

READY TO GO IN JUST
10
SECONDS

INSTANT PEELED PINEAPPLE

CORED OR SPEARS

GRAB ATTENTION



- ENHANCE YOUR PRODUCE DEPARTMENT
- BOOST STORE SALES THROUGH NEW REPEAT CUSTOMERS AND INCREASED FOOT TRAFFIC

GENUINELY FRESH PINEAPPLE

PICK YOUR PERFECT PINEAPPLE FOR PEELING

EASY TO CLEAN

CLEAN IN 10 MIN. BY TRAINED OPERATOR



BRANDING ATTENTION INSTANT FRESH EXPERIENCE EASY

USER EXPERIENCE

- EXCITING PRESENTATION FOR ALL AGES
- OFFERS THE BEST SELF-SERVICE, EASY TO USE

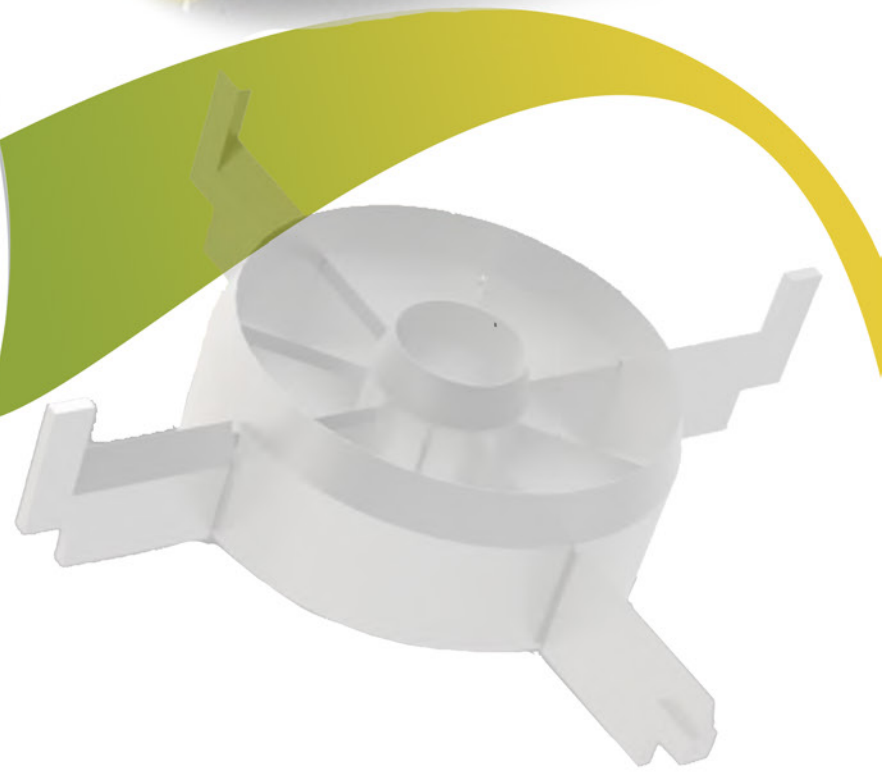
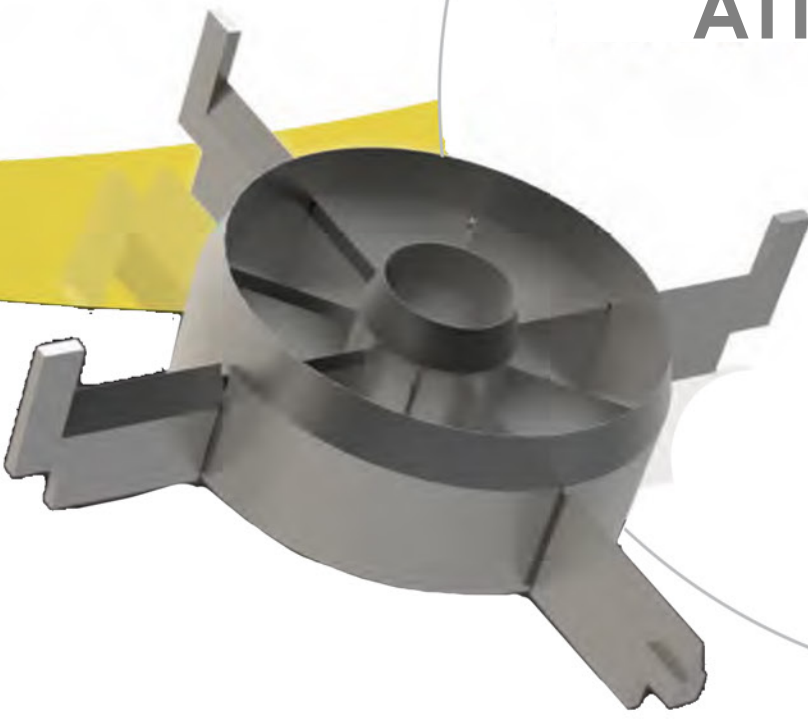

- BLADES AVAILABLE FOR PINEAPPLE TYPES 5,6,7,8,9
- EASY TO MOVE AROUND



BRANDING TOOL

- CUSTOMIZED WRAPS AVAILABLE



The Piñabar is a branding tool for your marketing department! It can be customized in style and color and can include your business logo in the custom wrap. Custom-made POS materials can also be arranged.



TECHNICAL DATA

PRODUCT SPECIFICATIONS:

Dimensions: 76"H x 29"W x 32"D

Weight: 796 lbs.

Color: Fully customizable

Blades: Available for pineapple types 5-9; always use the correct blade set for each size.

Waste container capacity: 40 lbs. of peel (25 pineapples)

Capacity: 5/min

Cleaning: We recommend cleaning once per day, at the end of each operational day.

Waste container and user manual included with each machine.

ELECTRICAL SPECIFICATIONS:

120V, 60Hz single phase 20 AMP

Service on a dedicated circuit.

Power: 350 watts

Sound level: < 70 dB

SHIPPING SPECIFICATIONS:

Height: 85 in.

Width: 48 in.

Depth: 48 in.

Weight: 796 lbs.

PINEAPPLE CONTAINER SPECIFICATIONS:

Use standard 32 oz. 4 1/2 x 5 1/2 inch deli container

WARRANTY:

1 year parts and labor

Piñabar is manufactured by:



www.dutchfoodtechnology.com



Piñabar is distributed by:



Since 1982, we have been specializing in juicers and corers with the highest quality equipment available in the industry today and have juicers that will process anything from apples to wheatgrass and even sugarcane.